

TR1102CAP

SMD CAP Ferrite Transponder Inductor

11.8x3.1x 2.6mm (2.38mH - 9.0mH)

SINGLE AXIS TRANSPONDERS INDUCTORS



FEATURES

The TR1102CAP series of surface mountable ferrite wound inductor is an evolution of the TR1102 series, and also one of the very first SMD coils designed for transponder use. Its length and cross sectional area are optimized to achieve the maximum sensitivity in the coil axis. And the use of high quality plastic material for the cap provides an additional mechanical protection to the coil with the thinnest walls, combined with a high performance in temperature.

01 CHARACTERISTICS

- › Size: 11.8 x 3.1 x 2.6 mm.
- › Terminals: Ag-Ni-Sn100.
- › Wire: H, 180°C, Solderable.
- › Max. Operating Temperature 125°C.

The TR1102CAP is a solution that combines the low cost and high-speed assembly of the circuit component, with the high mechanical protection provided by the cap, and it's excellent when the application demands a stronger coil.

02 SPECIFICATIONS

DIMENSIONS (mm)

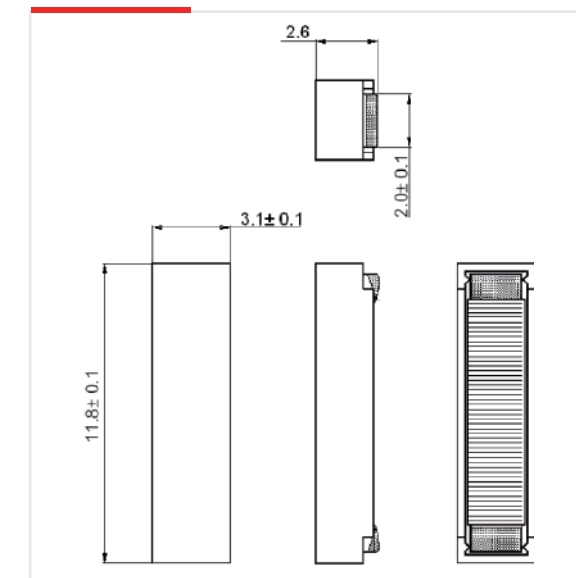

RECOMMENDED PAD-LAYOUT

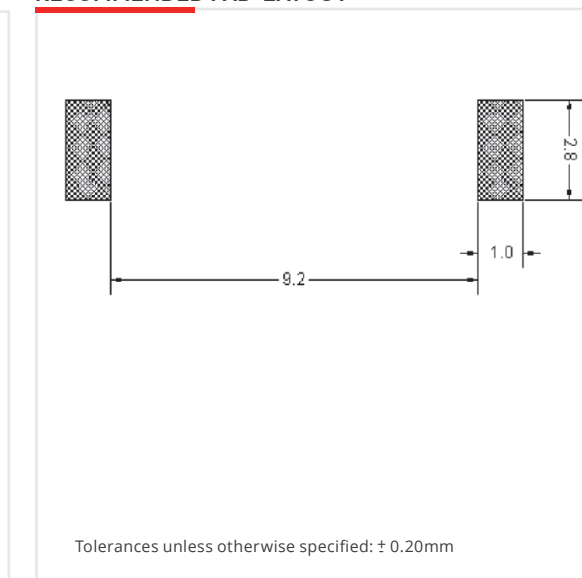

ELECTRICAL SPECIFICATIONS | 125KHz

Code	L@125 kHz (mH)	Q min. @125 kHz	SRF min. (kHz)	DCR MAX (Ohm)	Sensitivity min.@125 kHz (mVpp/App/m)
TR1102CAP-0238J	2.38 ±5%	25	500	40,7	35
TR1102CAP-0491J	4.91 ±5%	30	420	49	50
TR1102CAP-0720J	7.20 ±5%	27	330	90.2	70
TR1102CAP-0900J	9.00 ±5%	24.3	300	132	75

Inductance, Q factor, DCR and SRF measured with an LCR meter Wayne Kerr PMA 3260A.

The specification chart is a reference guide for the most common required values at working frequencies of 125 kHz. Any other inductance value at LF or tighter tolerances can be provided. Please contact our sales department for any inquiry.