

# PFT

## Three-Phase + Neutral Filters for General Use (3-150A)

### Electrical schematics

Only for 3/6/10/20Amp

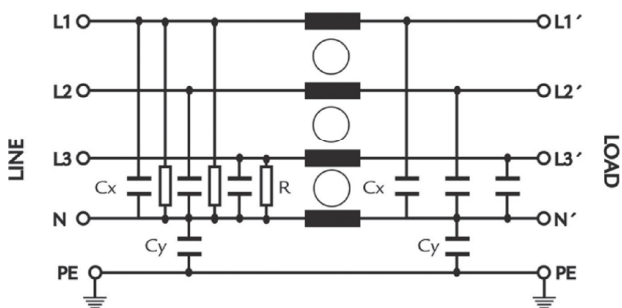
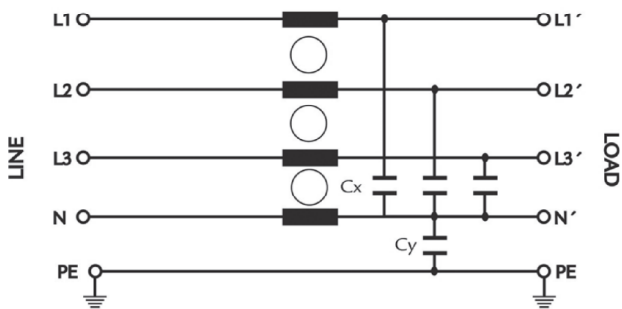

### General Specifications

Maximum operating voltage: 520Vac.

Operating frequency: DC - 60Hz.

Hipot test voltage: L/N->PE: 3000Vdc 2s.

L->N: 1300 Vdc 2s

Li->Lj: 2250 Vdc 2s.

Application class: HPF Acc. TO DIN 40040 (-25°C/+85°C/95% RH, 30d).

Flammability class: UL 94 V2.

### Three phase + Neutral filters

Single stage three phase + neutral filter. For switching applications.

### Product List

Type	I@40°C	L1	CX/CX'	CY	R	HOUSING	Max. Ifug mA IEC 950	Max. Ifug mA 400V 50Hz	CONNECTION	WEIGHT ±g
PFT-3Z	3 Amp	1 mH	0,1 µF	20 nF	--	401	485 µA	43 µA	FASTON 6,3mm	220
PFT-6Z	6 Amp	0,45 mH	0,1 µF	4,7 nF	--	401	485 µA	43 µA	FASTON 6,3mm	220
PFT-10Z	10 Amp	0,2 mH	0,1 µF	4,7 nF	--	401	485 µA	43 µA	FASTON 6,3mm	240
PFT-20Z	20 Amp	0,2 mH	0,1 µF	22 nF	--	401	1,9 mA	191 µA	FASTON 6,3mm	240
PFT-20W		0,2 mH	0,1 µF	22 nF		402	1,9 mA	191 µA	M6 SCREW	550
PFT-25B	25 Amp	1,3 mH	2,2 µF	15 nF	110 KΩ	403	3,2 mA	280 µA	4mm2	1500
PFT-25W						404			M6 SCREW	
PFT-36B	36 Amp	1 mH	2,2 µF	15 nF	110 KΩ	403	3,2 mA	280 µA	6mm2	1500
PFT-36W						404			M6 SCREW	
PFT-50B	50 Amp	0,55 mH	2,2µF/100 nF	15 nF	1MΩ	403	3,2 mA	280 µA	10mm2	1700
PFT-50W						404			M6 SCREW	
PFT-65B	65 Amp	0,36 mH	2,2 µF	22 nF	1MΩ	403	4,7 mA	412 µA	10mm2	1700
PFT-65W						404			M6 SCREW	
PFT-80B	80 Amp	0,5 mH	1 µF	22 nF	470kΩ	410	4,7 mA	410 µA	25mm2	3000
PFT-80W					470kΩ	412			M10 SCREW	
PFT-110B	110 Amp	0,25 mH	1 µF	22 nF		410	4,7 mA	410 µA	50mm2	3200
PFT-110W					470kΩ	412			M10 SCREW	
PFT-150B	150 Amp	0,25 mH	2,2 µF	22 nF		410	4,7 mA	412 µA	50mm2	3500
PFT-150W					110KΩ	412			M10 SCREW	

# PFT

## Three-Phase + Neutral Filters for General Use (3-150A)

Three Phase + Neutral Line Filters

### Insertion Loss

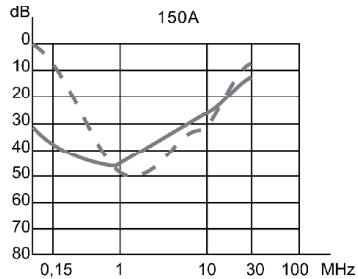
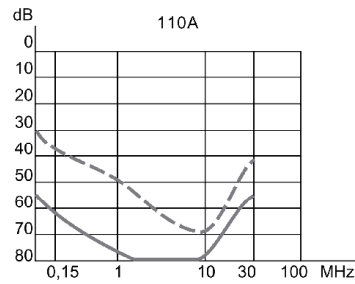
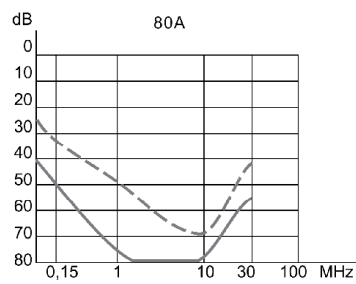
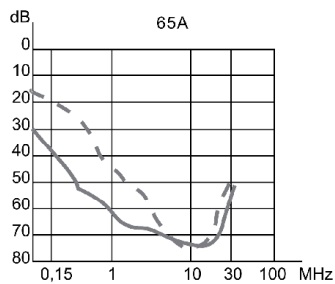
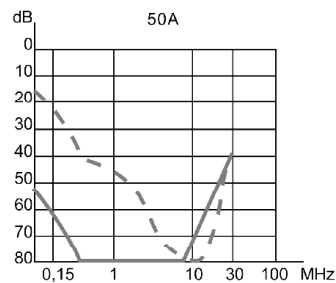
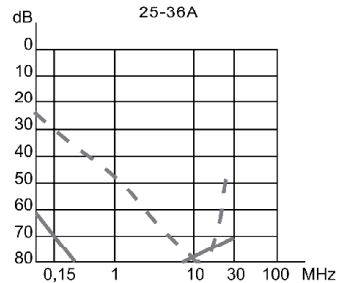
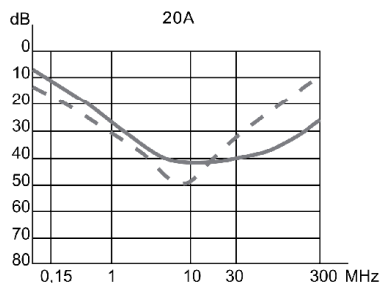
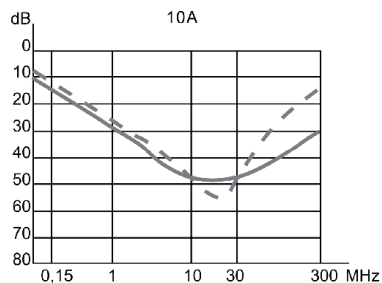
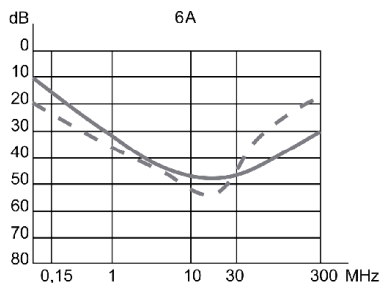
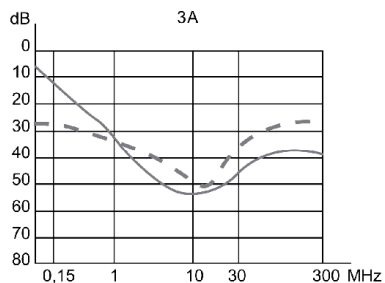

----- ASYM  
 ——— SYM