

New

KGEA-MR

Middle Range Antenna LF for smart entry system.

EMITTER ANTENNAS / MIDDLE RANGE



FEATURES

The Middle range antenna have been designed in order to reduce the number of antennas respect to the total number short antennas with equal or better performance reading distance and H-field around the whole vehicle.

01 CHARACTERISTICS

Depending on the requirements and location of the antennas in the vehicle and taking into account its exposure to environmental conditions, grade IP waterproof, mechanical robustness, etc.. PREMO offers from LPM technology, to Polyurethane, mixed LPM-resin and HPM.

New Middle Range Antenna with Low Pressure Technology (LPM)

- › LPM is a well know technology in PREMO
- › Vert fast to produce (No Curing needed)
- › IP56 grade Waterproof

New Middle Range Antenna with PU-resin

- › High mechanical robustness
- › IP68 grade Waterproof

THE MAIN TECHNICAL AND ECONOMIC ADVANTAGE

- › Middle antenna (length until 200mm).
- › External housing shape flat Material PBT-GF30% or PA66-GF30%
- › Anchor points (Clips and pivot).
- › High stability in temperature (-40°C up to +85°C).
- › Resonant frequency adjusting below +/- 2kHz.
- › Custom L-C value (F-Res: KGEA-MR) under demand
- › This antenna is designed based on AECQ-200.

02 SPECIFICATIONS

DIMENSIONS (mm)

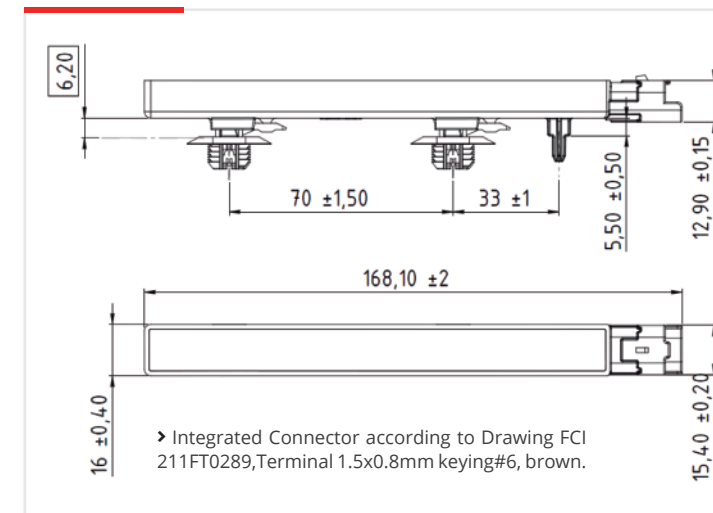

SCHEMATIC DIAGRAM

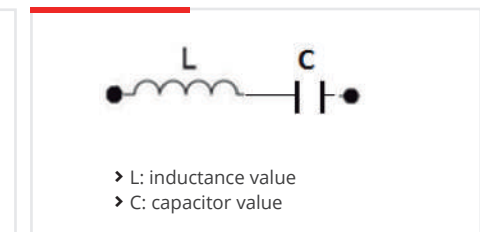

NOMENCLATURE

› L+C in series:

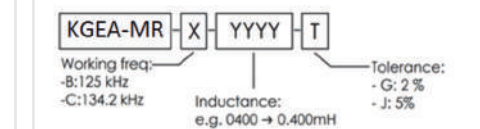

RECOMMENDED LANDPATTERN FOR TRW30413438

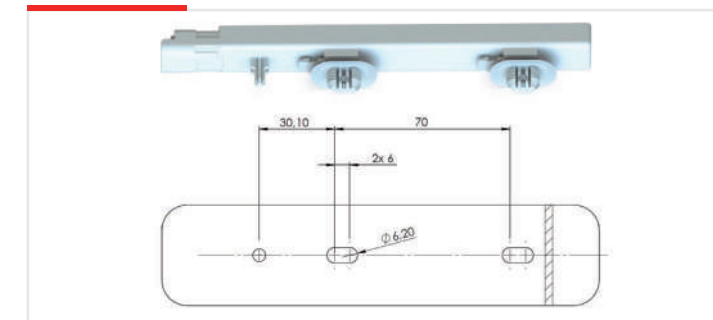

ELECTRICAL SPECIFICATIONS

Operating Frequency @125Khz @25°C @1Vac (L+C in series)

L(mH)	0.175
Cres (nF)	10
Q(L+C)	>145
Rac (Ω)	<1
Arms	1A
H-Field (dBμV/m) @2App@3m	140

› Antenna is measured in resonant mode. The specification chart is a reference guide for the most common required values at working frequencies of 125 kHz, 20 kHz and 134.2 kHz. Any other inductance

› value at LF or tighter tolerances can be provided. Please contact our sales department for any inquiry.

New

KGEA-MR

Middle Range Antenna LF for smart entry system.

EMITTER ANTENNAS / MIDDLE RANGE

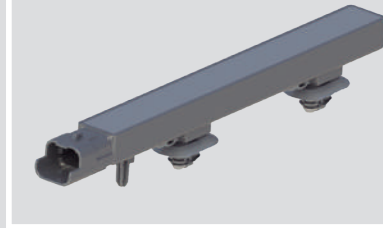

RADIATED H-field (Ipp)@distance:

PROCEDURE

- › Magnetic field probe measures in load $I_{pp}=2A_{pp}$ to 3meters @ $f_0=125KHz$
- › Receiving the signal from the probe field with the spectrum analyzer.

SETUP

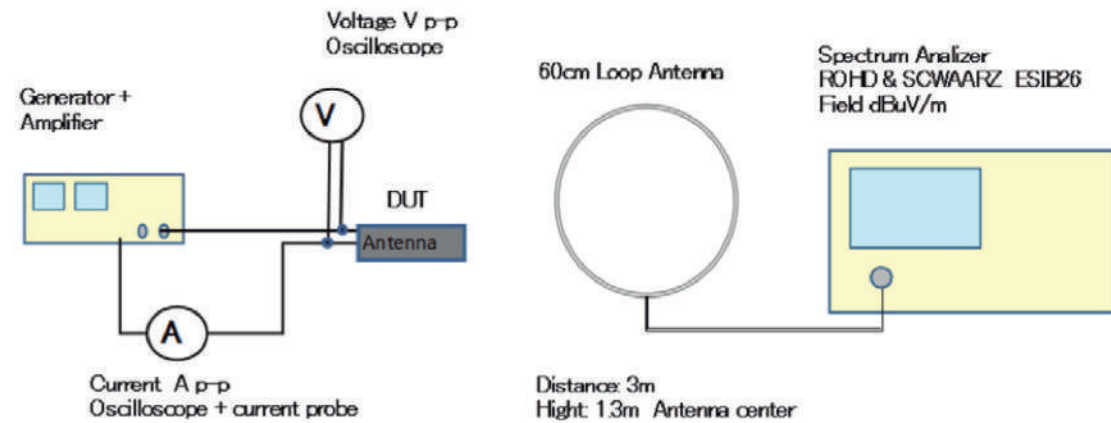

› The sample (antenna under test), the current flowing through it and the EM-field at 3m measured with a loop antenna (60cm) are obtained at 125Khz frequency.

› Note: Ipp is the current peak to peak measured with the oscilloscope

KGEA-MR-B-0175J / H-FIELD @125kHz @2App @3m

